

RCS3-RA8R Medium Thrust Rod Type (Servo Press Model with Load Cell)

Battery-less Absolute
Motor Unit Type
Side-mounted Motor
Body Width 90* mm
230v AC Servo Motor

Model Specification Items	RCS3	RA8R	WA	200	2.5	<input type="checkbox"/>	T2	<input type="checkbox"/>	<input type="checkbox"/>
	Series	Type	Encoder Type	Motor Type	Lead	Stroke	Applicable Controllers	Cable Length	Options
			WA: Battery-less Absolute	200: Servo motor 200W	2.5: Lead 2.5mm	100: 100mm 500: 500mm (Every 50mm)	T2: SCON-CB/CGB (For servo press only)	N : None P : 1m S : 3m M : 5m X□□ : Specified length R□□ : Robot cable	Refer to Options table below. * Specify cable exit direction (CJT/CJB/CJO). For side-mounted motor type, specify the mount direction (ML/MR).

* Does not include a controller.
 * Please contact IAI for more information about the model specification items.
 * Body width does not include the width of the side-mounted motor.

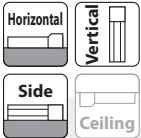

* Depending on the model, there may be some limitations to using the vertical mount position. Please contact IAI for more information.

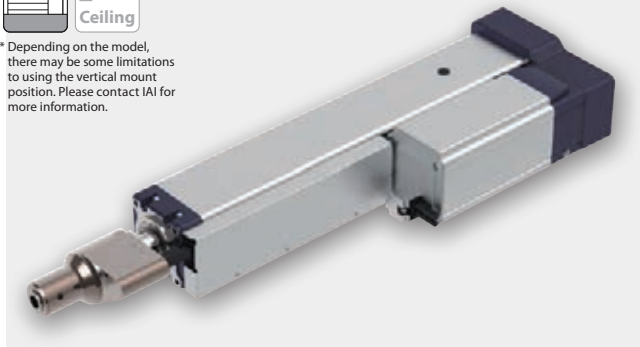

Correlation Diagram of Push Force and Current Limit Value

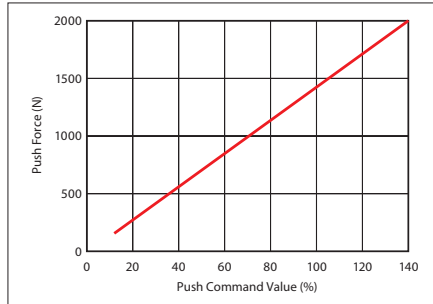

Caution:

- The correlation between push force and push command value are strictly for reference purposes. Actual numbers may vary slightly.
- The push command value should be 14% or more because the push force will be unstable when the push command value is low.

POINT Selection Notes

- (1) For push-motion operation, check the allowable time period of continuous push-motion set with a different thrust force. Also, please check that the allowable continuous operational thrust force for the actual push cycle is less than the allowable continuous operational thrust force. (Even if there is no push motion) Please refer to P.27 for more information.
- (2) Customer's tooling is to be mounted on the load cell itself. In case any radial or moment load is applied to the load cell, please consider adding the external guides, etc. to offset those side loads.
- (3) Please install a support block when front mounting or back mounting a horizontally mounted actuator that is 150st or more. (Refer to page 34 "Notes When Installing")
- (4) Servo Press with load cell should not be used for pulling motion. It will damage the load cell.

Actuator Specifications

Lead and Payload

Model Number	Motor wattage (W)	Lead (mm)	Max. speed (mm/s)	Max. acceleration (G)	Max. payload		Rated thrust (N)	Max. push force (N)
					Horizontal (kg)	Vertical (kg)		
RCS3-RA8R-WA-200-2.5-①-T2-②-③	200	2.5	125	0.2	10	10	1367	2000

Legend: ① Stroke ② Cable Length ③ Option * Max. horizontal payload means max. weight on the customer's external guide. ** Max. push force can be achieved only within 1~10mm/s speed range.

Stroke and Max Speed

Lead (mm)	Stroke (mm)	100~500
2.5		125

(Unit: mm/s)

Cable Length

Type	Cable Code
Standard	P(1m)
	S(3m)
	M(5m)
Specified length (Standard cable)	X06(6m) ~X10(10m)
	X11(11m)~X15(15m)
	X16(16m)~X20(20m)
Robot cable	R01(1m) ~R03(3m)
	R04(4m) ~R05(5m)
	R06(6m) ~R10(10m)
	R11(11m)~R15(15m)
	R16(16m)~R20(20m)

* Please contact IAI for maintenance cables.

Options

Name	Option Code	Reference Page
Brake	B	See P.35
Cable exit direction (Top)	CJT	See P.35
Cable exit direction (Bottom) (*2)	CJB	See P.35
Cable exit direction (Outside)	CJO	See P.35
Flange (Front)	FL	See P.35
Foot bracket (*1)	FT	See P.36
Equipped with load cell (Standard equipment) (*3)	LCT	See P.37
Motor side-mounted (left)	ML	See P.37
Motor side-mounted (right)	MR	See P.37

(*1) Refer to P. 37 for the number of brackets included.

(*2) The foot bracket cannot be chosen when you select the actuator whose stroke is 100mm.

(*3) Please make sure to enter "LCT" in the box of Model Specification Items to select the actuator with load cell option.

Actuator Specifications

Item	Description
Drive system	Ball screw ø16mm rolled C10
Positioning repeatability	±0.01mm
Lost motion	0.1mm or less
Load cell rated capacity	2000N
Loading repeatability (*1)	±0.5% F.S (*2)
Ambient operating temp. & humidity	0°C~40°C, 85% RH or less (non-condensing)

(*1) Ratio (in percentage) of the load variations caused by the repeated operations to the load cell rated capacity

(*2) F.S.: Full Scale, the maximum measurable value.

Dimensions

CAD drawings can be downloaded from our website.
www.robocylinder.de



*1 Connect the motor-encoder cables. Please contact IAI for more details on the cable.
*2 While the rod is returning to its home position, please be careful of interference from surrounding objects, as it will travel until it reaches the mechanical end.
M.E: Mechanical end
S.E: Stroke end

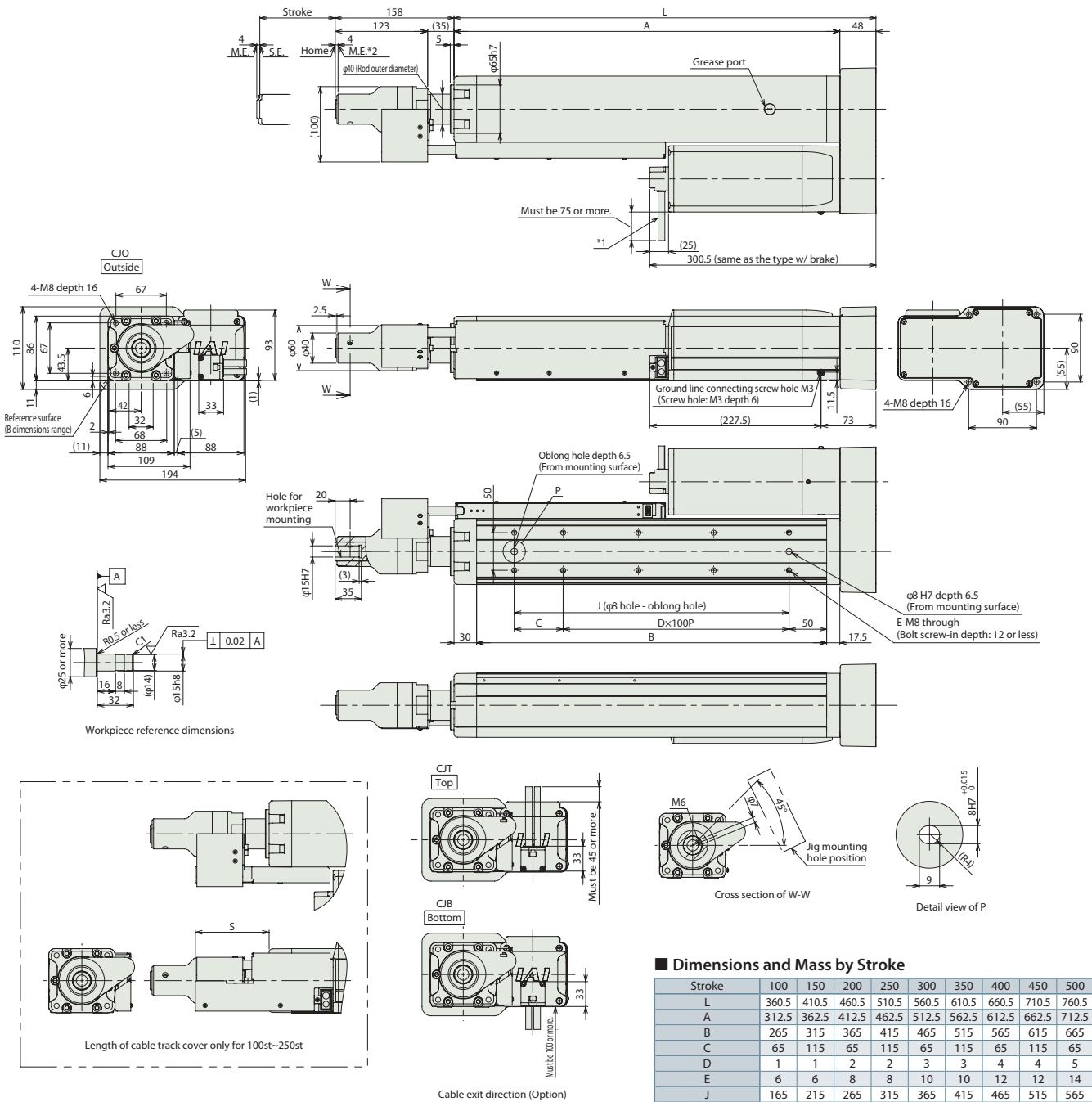

■ Dimensions and Mass by Stroke

Stroke	100	150	200	250	300	350	400	450	500
L	360.5	410.5	460.5	510.5	560.5	610.5	660.5	710.5	760.5
A	312.5	362.5	412.5	462.5	512.5	562.5	612.5	662.5	712.5
B	265	315	365	415	465	515	565	615	665
C	65	115	65	115	65	115	65	115	65
D	1	1	2	2	3	3	4	4	5
E	6	6	8	8	10	10	12	12	14
J	165	215	265	315	365	415	465	515	565
S	98	63	42	21	-	-	-	-	-
Mass (kg)									
Without brake	10.2	10.8	11.3	11.9	12.5	13	13.6	14.1	14.7
With brake	10.7	11.3	11.8	12.4	13.0	13.5	14.1	14.6	15.2

Applicable Controllers

The RCS3 series actuators can be operated by the controllers indicated below. Please select the type depending on your intended use.

Name	External view	Max. number of connectable axes	Power supply voltage	Control method				Network * Option	Maximum number of positioning points	Reference page
				Positioner	Pulse train	Program	Press program			
SCON-CB/CGB (For servo press only)		1	Single-phase 115VAC /230VAC	-	-	-	●	DeviceNet CC-Link EtherCAT EtherNet/IP CompoNet CANopen	-	Refer to the SCON-CB/CGB-F servo press function manual.